

PLAFON / PLAFOND / PLAFOND

# RING 3P

biały / white / weiß



💡 GU10, 3 x 40 W, 3 x 12 W LED \*

⚡ ~ 220-230 V, 50-60 Hz

📏 20 x 20 x 18 cm

🏠 stal / steel / Stahl

🌈 biały / white / weiß

📦 27 x 27 x 16 cm

📦 netto: 2,05 kg, brutto: 2,59 kg  
/ net: 2,05 kg, gross: 2,59 kg  
/ netz: 2,05 kg, brutto: 2,59 kg

💧 IP20



Podzespoły zastosowane w oprawach:

- oprawka GU10, 2 A, 250 V
- przewód przyłączeniowy 0,75 mm<sup>2</sup>
- złączki zaciskowe

/ Components used in luminaries:

- holder GU10, 2 A, 250 V
- connection cable 0,75 mm<sup>2</sup>
- compression fittings

/ Bauelemente der Fassungen:

- fassung GU10, 2 A, 250 V
- elektrische Leitung 0,75 mm<sup>2</sup>
- Klemmen

\* Źródło światła nie jest w komplecie / Light bulb not included / Leuchtmittel nicht inkl.



SL.1015

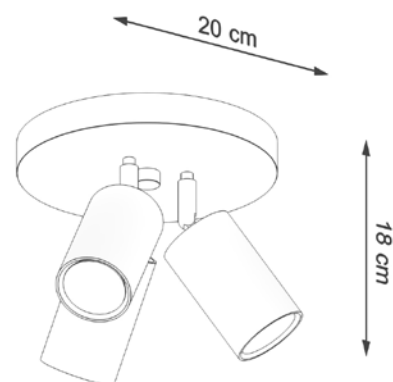

Made in EU