

PLAFON / PLAFOND / PLAFOND

RING 3P

czarny / black / schwarz



💡 GU10, 3 x 40 W, 3 x 12 W LED *

⚡ ~ 220-230 V, 50-60 Hz

📏 20 x 20 x 18 cm

🏠 stal / steel / Stahl

🎨 czarny / black / schwarz

📦 27 x 27 x 16 cm

📦 netto: 2,05 kg, brutto: 2,59 kg
/ net: 2,05 kg, gross: 2,59 kg
/ netz: 2,05 kg, brutto: 2,59 kg

🌧️ IP20



Podzespoły zastosowane w oprawach:

- oprawka GU10, 2 A, 250 V
- przewód przyłączeniowy 0,75 mm²
- złączki zaciskowe

/ Components used in luminaries:

- holder GU10, 2 A, 250 V
- connection cable 0,75 mm²
- compression fittings

/ Bauelemente der Fassungen:

- fassung GU10, 2 A, 250 V
- elektrische Leitung 0,75 mm²
- Klemmen

* Źródło światła nie jest w komplecie / Light bulb not included / Leuchtmittel nicht inkl.



SL.1016

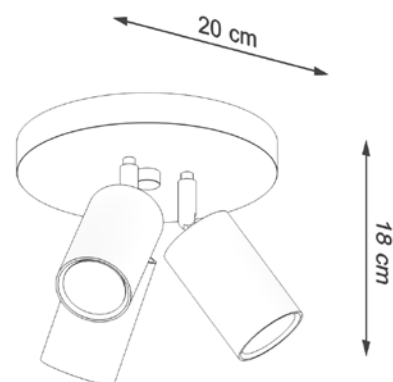

Made in EU