

PLAFON / PLAFOND / PLAFOND

RING 2

czarny / black / schwarz

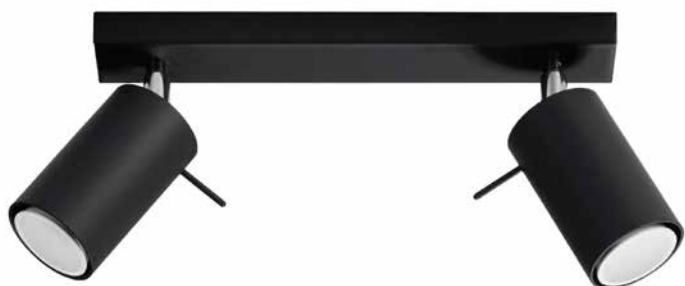

💡 GU10, 2 x 40 W, 2 x 12 W LED *

⚠️ ~ 220-230 V, 50-60 Hz

📏 30 x 6 x 16 cm

🏠 stal / steel / Stahl

🎨 czarny / black / schwarz

📦 17 x 10 x 10 cm

📦 netto: 1,05 kg, brutto: 1,20 kg
/ net: 1,05 kg, gross: 1,20 kg
/ netz: 1,05 kg, brutto: 1,20 kg

💧 IP20



Podzespoły zastosowane w oprawach:

- oprawka GU10, 2 A, 250 V
- przewód przyłączeniowy 0,75 mm²
- złączki zaciskowe

/ Components used in luminaires:

- holder GU10, 2 A, 250 V
- connection cable 0,75 mm²
- compression fittings

/ Bauelemente der Fassungen:

- fassung GU10, 2 A, 250 V
- elektrische Leitung 0,75 mm²
- Klemmen



SL.0092

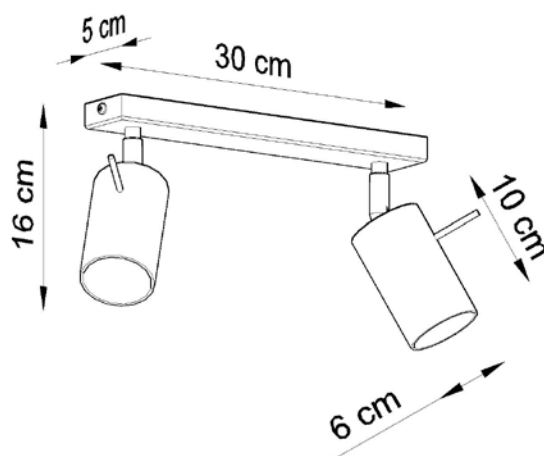

* Źródło światła nie jest w komplecie / Light bulb not included / Leuchtmittel nicht inkl.



Made in EU