

LAMPA BIURKOWA / TABLE LAMP / TISCHLAMPE

RING

biała / white / weiß



-  GU10, 1 x 40 W, 1 x 12 W LED *
-  ~ 220-230 V, 50-60 Hz
-  14,5 x 19,5 x 43 cm  6/10 cm
-  stal / steel / Stahl
-  biały / white / weiß
-  18 x 13 x 46,5 cm
-  netto: 1,1 kg, brutto: 1,3 kg
/ net: 1,1 kg, gross: 1,3 kg
/ netz: 1,1 kg, brutto: 1,3 kg



Podzespoły zastosowane w oprawach:

- oprawka GU10, 2 A, 250 V
- przewód przyłączeniowy 0,75 mm²
- złączki zaciskowe

/ Components used in luminaries:

- holder GU10, 2 A, 250 V
- connection cable 0,75 mm²
- compression fittings

/ Bauelemente der Fassungen:

- fassung GU10, 2 A, 250 V
- elektrische Leitung 0,75 mm²
- Klemmen

* Źródło światła nie jest w komplecie / Light bulb not included / Leuchtmittel nicht inkl.



SL.1090

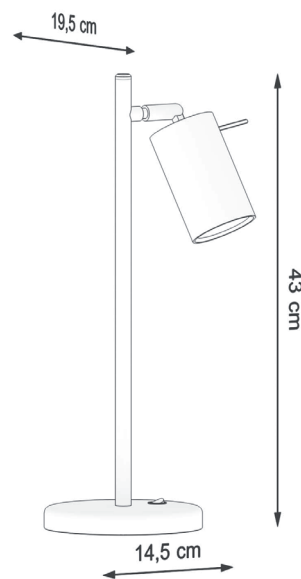

Made in EU